

# Digital Radiometer

EC1 IR



EC1-X IR

زیست تجهیز پویش

(سهامی خاص)



آدرس: تهران - خ مطهری - خ فجر - ک افشار - پ ۱۸

تلفن: ۸۸۸۲۷۷۲۳ - ۸۸۸۴۶۸۷۵ - فکس: ۸۸۸۴۶۷۹۱

پست الکترونیکی: info@PooyeshEnviro.ir

# The Hagner EC1 IR Digital Radiometer

## General description

The Hagner Digital Radiometer, model EC1 IR, is a small, handy and easy-to-use instrument for accurate measurement of radiation over a range of 0.01-20,000 W/m<sup>2</sup>. With both automatic zeroing and on/off switch, the only controls needed are a four-position range selection switch and a hold button for retaining the display value.

## Operation

To open the lid, press the forward part lightly downward with your thumb and at the same time pull the latch upwards with the first two fingers of the same hand. The radiometer comes on when the cover is opened and turns off when it is closed. Move the range switch to the range which will give the greatest accuracy and read the display. The hold function keeps the reading on the display until the hold button is released. Full instructions can be found on the inside of the cover.

## Maintenance

The power source is a standard 9 volt battery. To avoid battery leakage only alkaline batteries should be used. When LOBAT appears on the display, it is time to replace the battery. However the radiometer can be used for approximately 20 hours longer before replacing is necessary.

Change the battery by removing the screw at the front edge of the cover plate, which permits the plate to be lifted up and removed. When replacing it the lower edge of the plate must fit under the two bosses at the lower edge of the case before it can be closed again. The white plas-tic disc over the detector may be cleaned when necessary with a light damp cloth.

## Calibration

The radiometer is carefully calibrated when delivered. As the light sensitive silicon diodes are extremely stable over long periods of time recalibration every two-three years should, under normal use of the instrument, be sufficient. If however there is any reason to believe that the instrument is out of calibration, it can be returned to your stockist or the manufacturer for earlier control checks.

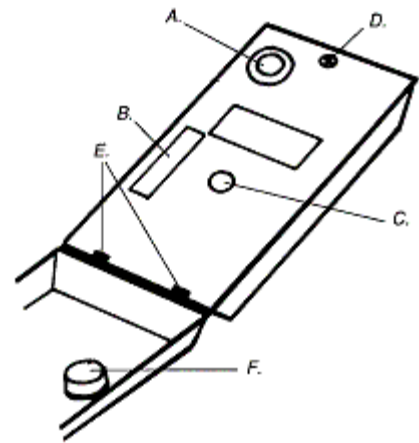

The controls and other parts of the Photometer  
 A Detector  
 B Range switch  
 C Holdbutton  
 D Screw for coverplate  
 E Locking bosses for the coverplate  
 F Magnet that switches the instrument on and off

# The Hagner EC1-X Digital Radiometer

The EC1-X IR has been designed for measurement of radiation levels in places where it is important that the operator does not shade the detector. The EC1-X IR has the detector connected with a 2 meter long cable. An extension cable can also be connected.

## Operation

The EC1-X IR is used exactly as the EC1. The detector can be connected or disconnected without causing any damage to the instrument. Care should be taken to ensure that the cable is not twisted when replacing the cable. It is recommended that the detector is rotated rather than winding the cable around the detector.

## Please note

The detector is individually calibrated to the respective instrument and can not be interchanged with other detectors. Check carefully that the instrument number in the cover corresponds with the number of the detector.

## Instrument data for EC1 IR and EC1-X IR

Detector	Silicon photodiode, filtered and cosine corrected.
Measuring range	0.01- 20,000 W/m <sup>2</sup>
Spectral sensitivity	750 - 1150 nm
Accuracy	Better than ±3% (±1 in last digit)
Power supply	9 volt battery type PP3 alkaline (lifetime approx. 350 hrs)
Dimensions	135 x 75 x 35 mm
Weight	0.19 kg (EC1-X IR 0.5 kg with carrying case)

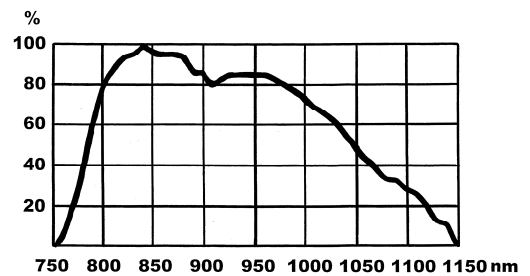

The spectral sensitivity of the Hagner Radiometer EC1 IR.

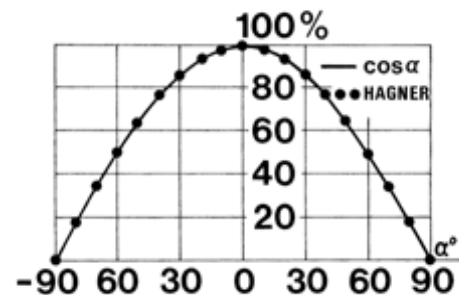

The cosine correction compensates for measuring errors owing to oblique

B. Hagner AB, Box 2256, SE-169 02 Solna, Sweden

Phone: +46 8 83 61 50 Fax: +46 8 83 93 57

E-mail: [hagner@hagner.se](mailto:hagner@hagner.se)